

Technical Data Sheet Armal SUN 600V M3 Vacuum Tank Unit

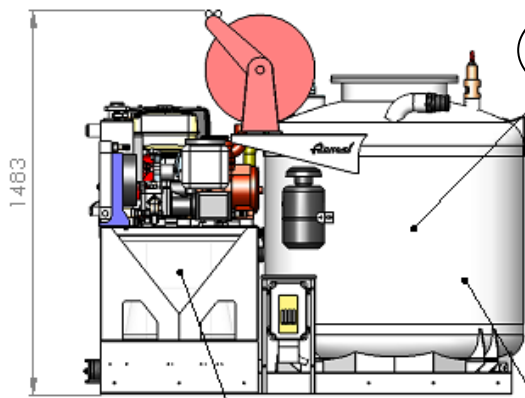
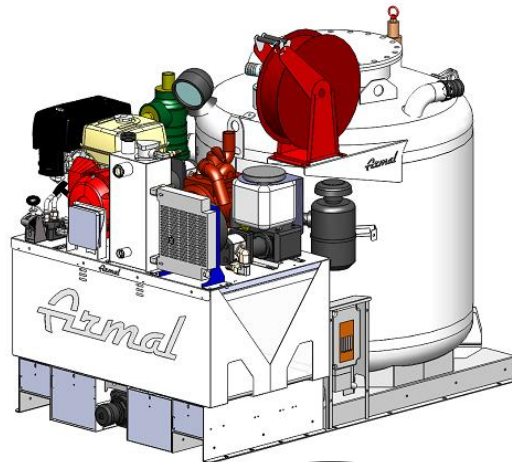

Fresh Water Capacity: 200 L / 52.83

Gray Water Capacity:
600 L/158.50 gal.

Thickness of the Tank
Sheet: 4 mm/0.15"

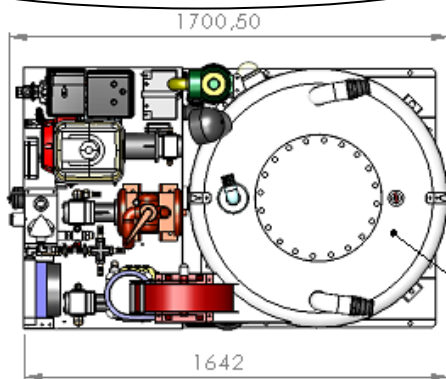
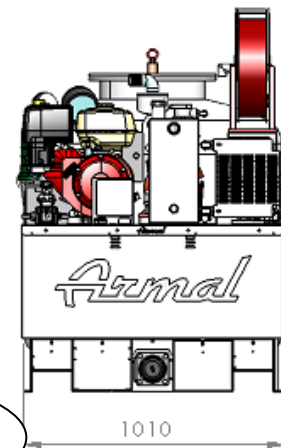

Thickness of the Bottom Tank
Sheet in Deep-drawn: 4
mm/0.15"

DESCRIPTION: Engine Driven Light Vacuum Tank Unit with Hydraulic System and Remote Control / 600 L/158.50 gal. gray water tank capacity and 200L/52.83 gal. fresh water tank capacity (purchase item No. 600VM3).



Technical Data Sheet

Armal SUN 600V M3 Vacuum Tank Unit

SPECIFICATIONS:

Height (max.)	1.500 mm / 59.05"
Width (max.)	1.010 mm / 39.76"
Length (max.)	1.650 mm / 64.96"
Diameter	1.000 mm / 39.37" (vertical)
Gray water capacity	600 L / 158.50 gal. approx.
Fresh water capacity	200 L / 52.83 gal. approx.
Weight in running order	500 kg / 1102.31 lb.
Length of the gray water suction hose	9,50 m / 374.02"
Length of the washing hose	15 m / 590.55"
Hydraulic oil tank capacity	8 L (7 kg) / 2.11 gal. (15.43 lb.)
Sanitary concentrate tank capacity	5 L / 1.32 gal.
Water pump max. performance (mod. AR XM15.15N)	15 L/min. / 3.96 gal./min. – 150 bar / 2175.57 psi @ 1.450 rpm
Vacuum pump with blades max performance (mod. BP MEC1600P)	1.980 L/min. / 523.06 gal./min. (air)@1.400 rpm
Thickness of the tank sheet	4 mm / 0.15"
Thickness of the bottom tank sheet in deep-drawn	4 mm / 0.15"
Engine	Honda GX270/gasoline
Hydraulic pump (mod. META P0206DH)	06 cm3 / 0.36 in3 @ 3.000 rpm 210 bar / 3045.79 psi max.
Material used	Main tank body made of carbon steel; fresh water tank in plastic material

FEATURES:

Description	Standard	Optional (*)
Eight cycle internal combustion Honda engine mod. GX270 with recoil and electric start (battery included)	x	
Remote control	x	
Electric drive controls on left and right side of the unit	n.a.	n.a.
Air-oil heat exchanger with electric fan	x	
Reduced hydraulic oil tank capacity: 8 litres/2.11 gallons	x	
Electrically operated hydraulic control valve with handle for emergency manual controls	x	
Combined operations system	n.a.	n.a.
Deodorizing control system		x
Vacuum pump filter-silencer	x	
Courtesy night light	x	
LED working light with automatic 10 metres/393.70" cable reel	n.a.	n.a.
High pressure water pump 15 litres/min.-3.96 gallons/min. - 150 bar -2175.57 psi	x	
High pressure water pump 11 litres/min.-2.90 gallons/min. - 170 bar- 2465.64 psi		x
No. 2 gray water suction hoses 9,50 metres/374.02" long complete with syringes	x	
No. 1 automatic hose reel with 15 metres/590.55" washing hose and double barrel spray washing gun with high pressure nozzle and low pressure outlet	x	
No. 2 automatic hose reels with 20 metres/787.40" washing hoses		x
Sanitary concentrate manual injector	x	
Electric drive of the sanitary concentrate		x
Cartridge oil filter and magnetic cap	x	
Fresh water tank in plastic materiel	x	
No. 1 sight transparent bowl to indicate the gray water tank maximum level	x	
Ball overflow valve and siphon valve	x	
Safety relief valve	x	



Technical Data Sheet
Armal SUN 600V M3 Vacuum Tank Unit

FEATURES:

Description	Standard	Optional (*)
Emergency stop controls on the unit	x	
Electrical level sensors with warning lights that light up when the gray water maximum level is reached	x	
Security system during the suction while reaching the maximum gray water level		x
Magnetic work spotlight (radio-controlled)	n.a.	n.a.
Hour counter device	x	

(*) n.a. = not available.

All technical data are approx. and non-binding. Armal S.p.A. reserves the right to make any changes at any time without notice.

Rev. 05 dd 28/11/2023

p. 3/3