

Technical Data Sheet Armal EASY 1100T B1 Vacuum Tank Unit

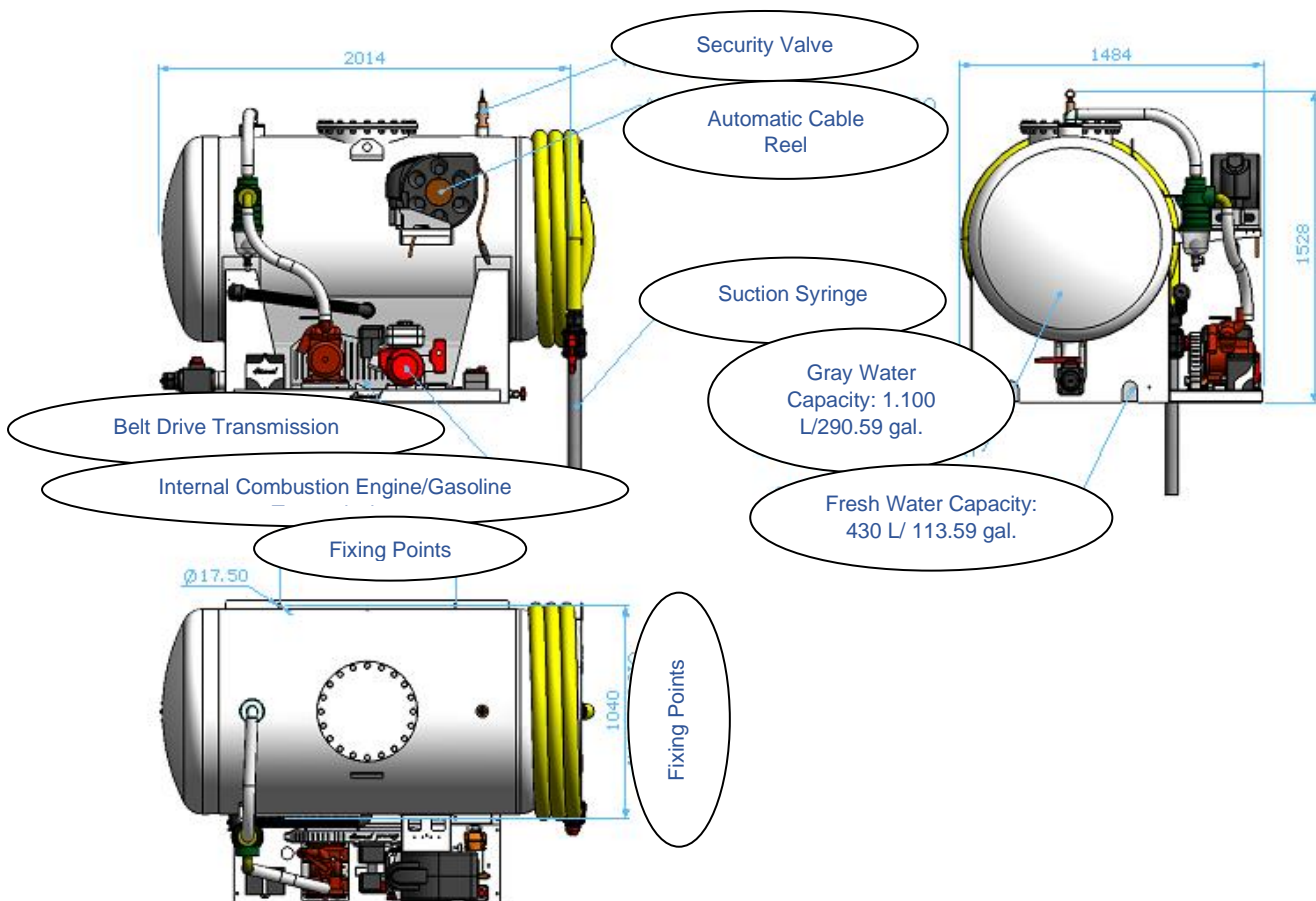

DESCRIPTION: Engine Driven Vacuum Tank Unit with Belt Drive System / Transversal positioning with 1.100 L/290.59 gal. gray water tank capacity and 430 L/113.59 gal. fresh water tank capacity (purchase item No. 1100TB1).

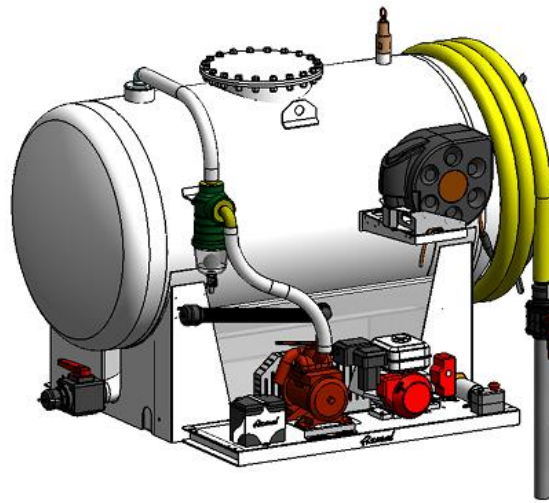

Technical Data Sheet

Armal EASY 1100T B1 Vacuum Tank Unit

SPECIFICATIONS:

Height (max.)	1.530 mm / 60.23"
Width (max.)	2.100 mm / 82.67"
Length (max.)	1.490 mm / 58.66"
Diameter	1.000 mm / 39.37"
Gray water capacity	1.100 L / 290.59 gal. approx.
Fresh water capacity	430 L / 113.59 gal. approx.
Weight in running order	560 kg / 1234.69 lb.
Length of the gray water suction hose	9,50 m / 374.02"
Length of the washing hose	10 m / 393.70"
Water pump max. performance (mod. UP2-P 12V)	5 L/min. / 1.32 gal./min. – 1.5 bar / 21.75 psi
Vacuum pump with blades max performance (mod. BP MEC1600P)	1.980 L/min. / 523.06 gal./min. (air)@1.400 rpm
Thickness of the tank sheet	4 mm / 0.15"
Thickness of the bottom tank sheet in deep-drawn	4 mm / 0.15"
Engine	Honda GX160/gasoline
Material used	Main tank body made of carbon steel; fresh water tank in semi-transparent plastic material

FEATURES:

Description	Standard	Optional
Honda engine mod. GX160 with recoil and electric start	x	
Water pump max. performance: 15 litres/min. – 3.96 gallons/min. – 5 bar / 72.51 psi		x
Vacuum pump filter-silencer		x
No. 1 gray water suction hose 9,50 metres/374.02" long complete with syringe	x	
No. 1 automatic hose reel with 10 metres/393.70" washing hose (low pressure)	x	
Fresh water tank in semi-transparent plastic material	x	
Ball overflow valve and siphon valve	x	
Safety relief valve	x	
No. 2 sight glass bowls to check gray water level placed on both sides of the tank	x	
No. 3 plastic level sight glasses to check the fresh water tank level	x	
Manhole on the gray water tank to allow operators to check its interior and to clean it in case of extraordinary maintenance operations	x	

All technical data are approx. and non-binding. Armal S.p.A. reserves the right to make any changes at any time without notice.

Rev. 04 dd 28/11/2023

p. 2/2