

Technical Data Sheet Armal EASY 2000T B1 Vacuum Tank Unit

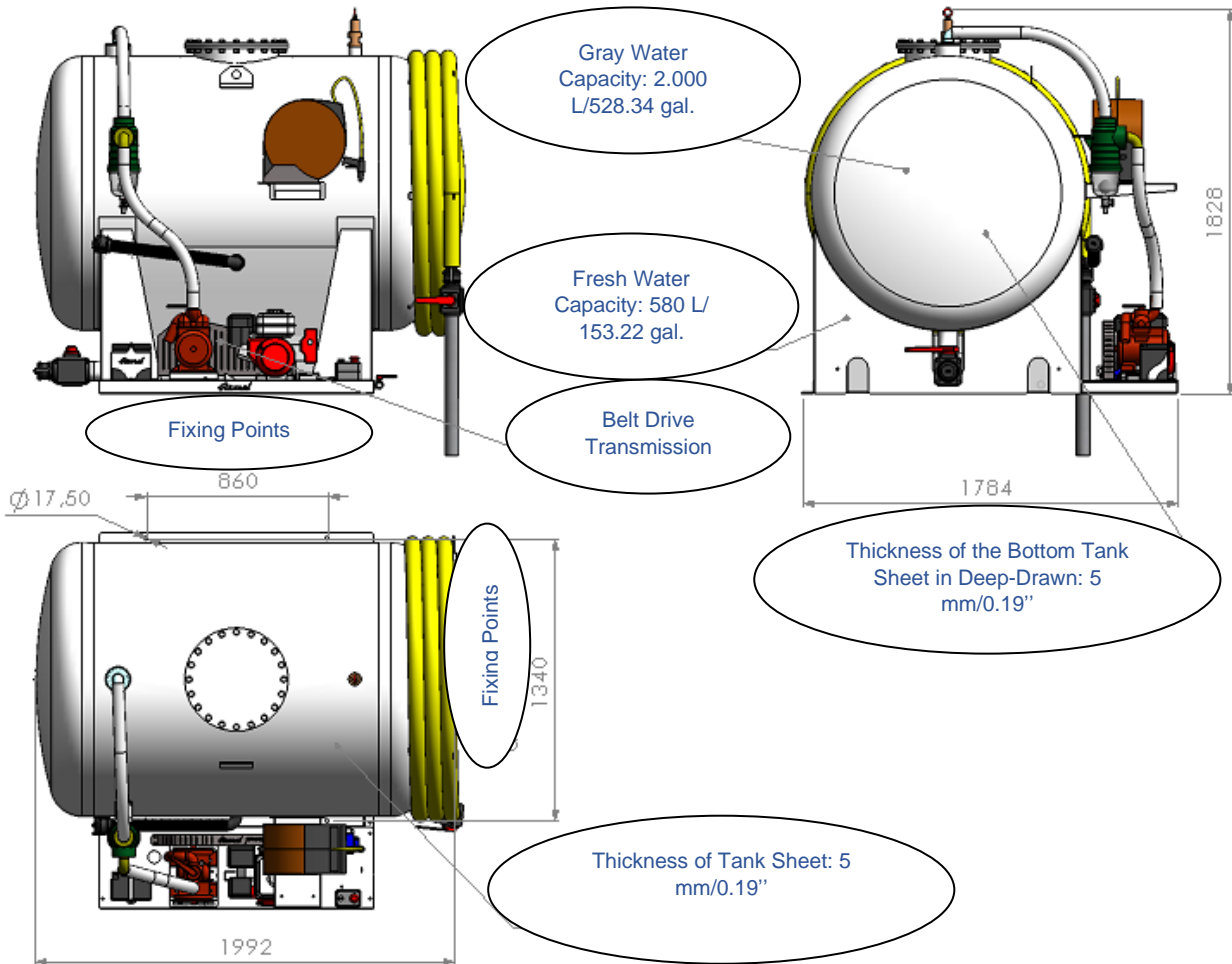

DESCRIPTION: Engine Driven Vacuum Tank Unit with Belt Drive System / Transversal positioning with 2.000 L/528.34 gal. gray water tank capacity and 580 L/153.22 gal. fresh water tank capacity (purchase item No. 2000TB1).

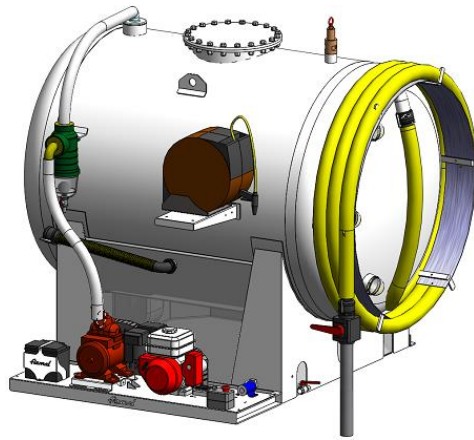

Technical Data Sheet

Armal EASY 2000T B1 Vacuum Tank Unit

SPECIFICATIONS:

Height (max.)	1.830 mm / 72.04"
Width (max.)	2.000 mm / 78.74"
Length (max.)	1.790 mm / 70.47"
Diameter	1.300 mm / 51.18"
Gray water capacity	2.000 L / 528.34 gal. approx.
Fresh water capacity	580 L / 153.22 gal. approx.
Weight in running order	730 kg / 1609.37 lb.
Length of the gray water suction hose	12,50 m / 492.13"
Length of the washing hose	10 m / 393.70"
Water pump max. performance (mod. UP2-P 12V)	5 L/min. / 1.32 gal./min. – 1.5 bar / 21.75 psi
Vacuum pump with blades max performance (mod. BP MEC1600P)	1.980 L/min. / 523.06 gal. (air)@1.400 rpm
Thickness of the tank sheet	5 mm / 0.19"
Thickness of the bottom tank sheet in deep-drawn	5 mm / 0.19"
Engine	Honda GX160/gasoline
Material used	Main tank body made of carbon steel; fresh water tank in semi-transparent plastic material

FEATURES:

Description	Standard	Optional
Honda engine mod. GX160 with recoil and electric start	x	
Water pump max. performance: 15 litres/min. – 3.96 gallons/min. – 5 bar / 72.51 psi		x
Vacuum pump filter-silencer		x
No. 1 gray water suction hose 12,50 metres/492.13" long complete with syringe	x	
No. 1 automatic hose reel with 10 metres/393.70" washing hose (low pressure)	x	
Fresh water tank in semi-transparent plastic material	x	
Ball overflow valve and siphon valve	x	
Safety relief valve	x	
No. 3 sight glass bowls to check gray water level placed on both sides of the tank	x	
No. 3 plastic level sight glasses to check the fresh water tank level	x	
Manhole on the gray water tank to allow operators to check its interior and to clean it in case of extraordinary maintenance operations	x	

All technical data are approx. and non-binding. Armal S.p.A. reserves the right to make any changes at any time without notice.

Rev. 04 dd 28/11/2023

p. 2/2