

## Technical Data Sheet Armal SUN 2000T M2 Vacuum Tank Unit

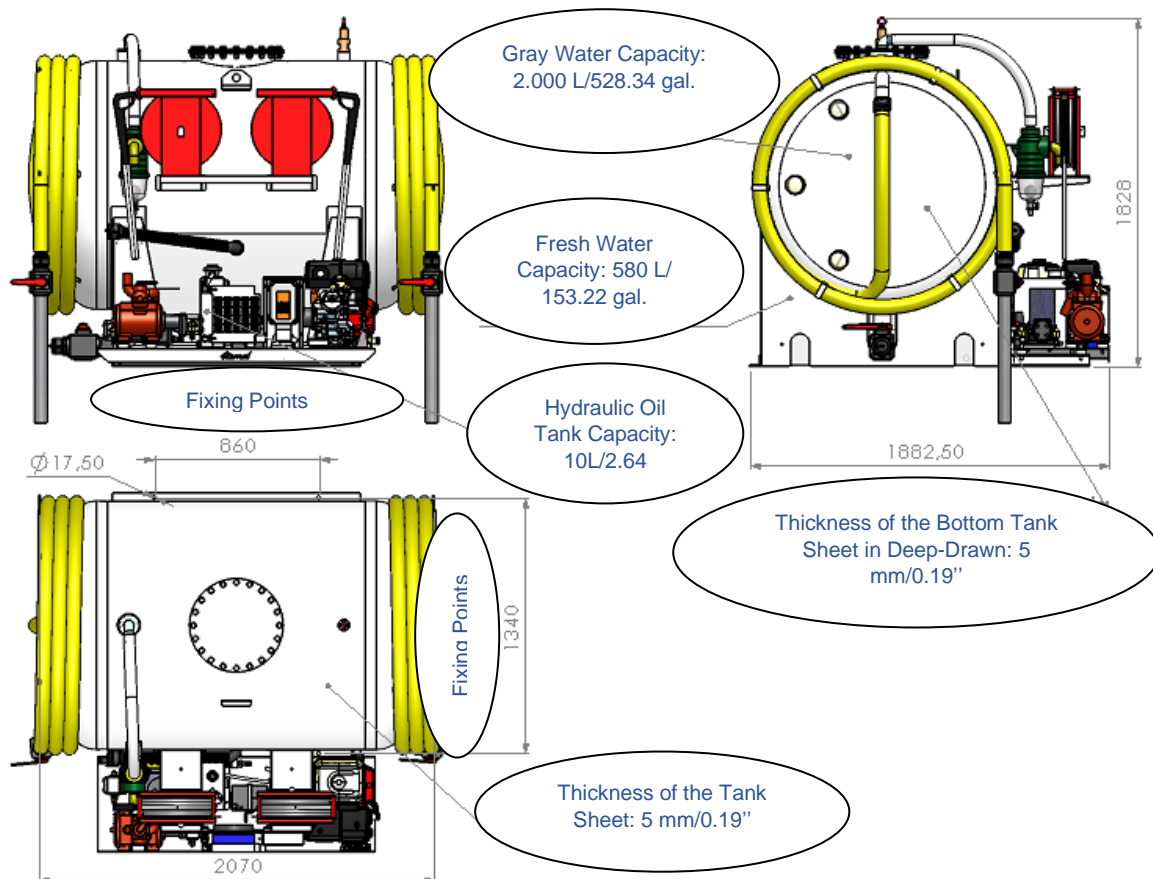

**DESCRIPTION:** Engine Driven Vacuum Tank Unit with Hydraulic System and Remote Control / Transversal positioning with 2.000 L/528.34 gal. gray water tank capacity and 580 L/153.22 gal. fresh water tank capacity (purchase item No. 2000TM2).

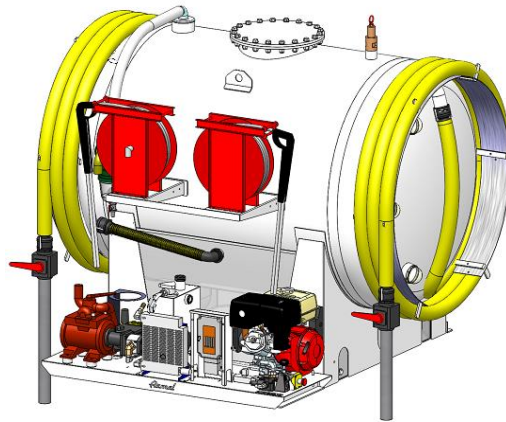

## Technical Data Sheet

### Armal SUN 2000T M2 Vacuum Tank Unit

#### SPECIFICATIONS:

|  |  |
|--|--|
| Height (max.)  | 1.830 mm / 72.04"  |
| Width (max.)   | 2.100 mm / 82.67"  |
| Length (max.)  | 1.885 mm / 74.21"  |
| Diameter   | 1.300 mm / 51.18"  |
| Gray water capacity  | 2.000 L / 528.34 gal. approx.  |
| Fresh water capacity                                       | 580 L / 153.22 gal. approx.  |
| Weight in running order                                    | 800 kg / 1763.7 lb.  |
| Length of the gray water suction hose                      | 12 m / 442.44"   |
| Length of the washing hose                                 | 15 m / 590.55"   |
| Hydraulic oil tank capacity                                | 10 L (9 kg) / 2.64 gal. (19.84 lb.)  |
| Sanitary concentrate tank capacity                         | 5 L / 1.32 gal.  |
| Water pump max. performance (mod. AR XM15.15N)             | 15 L/min. / 3.96 gal./min. – 150 bar / 2175.57 psi @ 1.450 rpm                             |
| Vacuum pump with blades max performance (mod. BP MEC1600P) | 1.980 L/min. / 523.06 gal./min. (air)@1.400 rpm  |
| Thickness of the tank sheet                                | 5 mm / 0.19"   |
| Thickness of the bottom tank sheet in deep-drawn           | 5 mm / 0.19"   |
| Engine   | Honda GX270/gasoline   |
| Hydraulic pump (mod. META P0206DH)                         | 06 cm <sup>3</sup> / 0.36 in <sup>3</sup> @ 3.000 rpm 210 bar / 3045.79 psi max.           |
| Material used  | Main tank body made of carbon steel; fresh water tank in semi-transparent plastic material |

#### FEATURES:

| Description  | Standard | Optional |
|--|----------|----------|
| Eight cycle internal combustion Honda engine mod. GX270 with recoil and electric start (battery included)  | x        |          |
| Remote control   | x        |          |
| Electric drive controls on left and right side of the unit   | x        |          |
| Air-oil heat exchanger with electric fan   | x        |          |
| Reduced hydraulic oil tank capacity: 10 litres/2.64 gallons  | x        |          |
| Electrically operated hydraulic control valve with handle for emergency manual controls  | x        |          |
| Combined operations system   |          | x        |
| Deodorizing control system   |          | x        |
| Vacuum pump filter-silencer  | x        |          |
| Courtesy night light   | x        |          |
| LED working light with automatic 10 metres/393.70" cable reel  | x        |          |
| High pressure water pump 15 litres/min.-3.96 gallons/min. - 150 bar -2175.57 psi   | x        |          |
| High pressure water pump 11 litres/min.-2.90 gallons/min. - 170 bar- 2465.64 psi   |          | x        |
| No. 2 gray water suction hoses 12 metres/472.44" long complete with syringes   | x        |          |
| No. 2 automatic hose reels with 15 metres/590.55" washing hoses and double barrel spray washing guns with high pressure nozzle and low pressure outlet | x        |          |
| No. 2 automatic hose reels with 20 metres/787.40" washing hoses  |          | x        |
| Sanitary concentrate tank capacity: 19 litres/5 gallons  |          | x        |
| Sanitary concentrate manual injector   | x        |          |
| Electric drive of the sanitary concentrate   |          | x        |
| Cartridge oil filter and magnetic cap  | x        |          |
| Fresh water tank in semi-transparent plastic material  | x        |          |
| No. 3 sight glass bowls to check gray water level placed on both sides of the tank   | x        |          |
| No. 3 plastic level sight glasses to check the fresh water tank level  | x        |          |
| Ball overflow valve and siphon valve   | x        |          |



**Technical Data Sheet**  
**Armal SUN 2000T M2 Vacuum Tank Unit**

**FEATURES:**

| Description                                | Standard | Optional |
|--|----------|----------|
| Safety relief valve                        | x        |          |
| Emergency stop controls on the unit        | x        |          |
| Magnetic work spotlight (radio-controlled) |          | x        |
| Hour counter device                        | x        |          |

**FEATURES:**

| Description                                | Standard | Optional |
|--|----------|----------|
| Safety relief valve                        | x        |          |
| Emergency stop controls on the unit        | x        |          |
| Magnetic work spotlight (radio-controlled) |          | x        |
| Hour counter device                        | x        |          |

All technical data are approx. and non-binding. Armal S.p.A. reserves the right to make any changes at any time without notice.