

## Technical Data Sheet Armal TRK 1100T P2 Vacuum Tank Unit

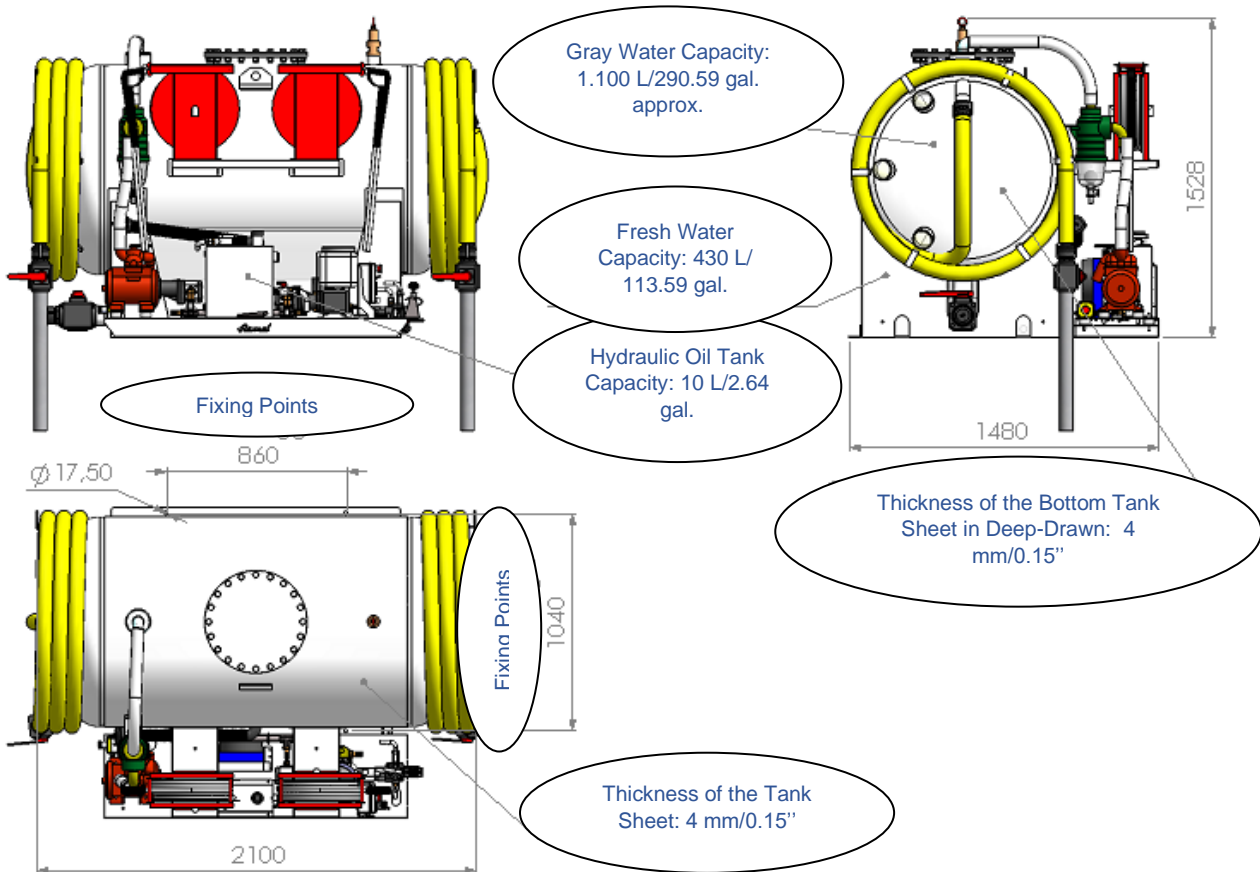

**DESCRIPTION:** Vacuum Tank Unit driven by PTO (Power Take Off) and Remote Control / Transversal positioning with 1.100 L/290.59 gal. gray water tank capacity and 430 L/113.59 gal. fresh water tank capacity (purchase item No. 1100TP2).

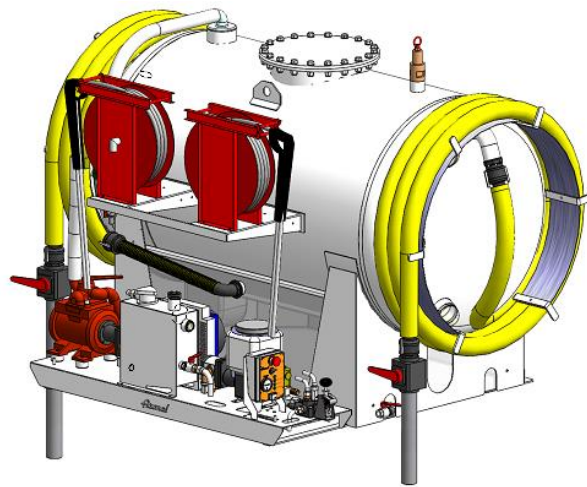

## Technical Data Sheet

### Armal TRK 1100T P2 Vacuum Tank Unit

#### SPECIFICATIONS:

Height (max.)	1.530 mm / 60.23"
Width (max.)	2.100 mm / 82.67"
Length (max.)	1.480 mm / 58.26"
Diameter	1.000 mm / 39.37"
Gray water capacity	1.100 L / 290.59 gal. approx.
Fresh water capacity	430 L / 113.59 gal. approx.
Weight in running order	580 kg / 1278.68 lb.
Length of the gray water suction hose	9,50 m / 374.02"
Length of the washing hose	15 m / 590.55"
Hydraulic oil tank capacity	10 L (9 kg) / 2.64 gal. (19.84 lb.)
Sanitary concentrate tank capacity	5 L / 1.32 gal.
Water pump max. performance (mod. AR XM15.15N)	15 L/min. / 3.96 gal./min. - 150 bar / 2175.57 psi @ 1.450 rpm
Vacuum pump with blades max performance (mod. BP MEC1600P)	1.980 L/min. / 523.06 gal./min. (air)@1.400 rpm
Thickness of the tank sheet	4 mm / 0.15"
Thickness of the bottom tank sheet in deep-drawn	4 mm / 0.15"
Material used	Main tank body made of carbon steel; fresh water tank in semi-transparent plastic material

#### FEATURES:

Description	Standard	Optional
Remote control	x	
Electric drive controls on left and right side of the unit	x	
Air-oil heat exchanger with electric fan	x	
Reduced hydraulic oil tank capacity (10 litres/2.64 gallons)	x	
Electrically operated hydraulic control valve with handle for emergency manual controls	x	
Combined operations system		x
Deodorizing control system		x
Vacuum pump filter-silencer	x	
Courtesy night light	x	
LED working light with automatic 10 metres/393.70" cable reel	x	
High pressure water pump 15 litres/min.-3.96 gallons/min. - 150 bar -2175.57 psi	x	
High pressure water pump 11 litres/min.-2.90 gallons/min. - 170 bar- 2465.64 psi		x
No. 2 gray water suction hoses 9,50 metres/374.02" long complete with syringes	x	
No. 2 automatic hose reels with 15 metres/590.55" washing hoses and double barrel spray washing guns with high pressure nozzle and low pressure outlet	x	
No. 2 automatic hose reels with 20 metres/787.40" washing hoses		x
Sanitary concentrate tank capacity: 19 litres/5 gallons		x
Sanitary concentrate manual injector	x	
Electric drive of the sanitary concentrate		x
Cartridge oil filter and magnetic cap	x	
Fresh water tank in semi-transparent plastic material	x	
No. 2 sight glass bowls to check gray water level placed on both sides of the tank	x	
No. 3 plastic level sight glasses to check the fresh water tank level	x	
Ball overflow valve and siphon valve	x	
Safety relief ball	x	
Emergency stop controls on the unit	x	
Magnetic work spotlight (radio-controlled)		x
Hour counter device	x	

All technical data are approx. and non-binding. Armal S.p.A. reserves the right to make any changes at any time without notice.

Rev. 03 dd 28/11/2023

p. 2/2